

TOLERANCE NOTES

FABRICATED TOLERANCES

≥ 2 ft (610 mm) ± 0.250 in (6.4 mm)
 < 2ft (610 mm) ± 0.125 in (3.2 mm)

MACHINED TOLERANCES

± 0.050 DECIMAL DIM (1 PLACE)
 ± 0.010 DECIMAL DIM (2 PLACES)
 ± 0.005 DECIMAL DIM (3 PLACES)

MNL-IVN

THIS DRAWING OWNED BY **CHENTRONICS**. IT IS CONDITIONALLY LOANED AND IS TO BE RETURNED UPON REQUEST. THE BORROWER BY RECEIVING IT HAS AGREED NOT TO REPRODUCE NOR COPY IT IN WHOLE OR IN PART NOR TO FURNISH INFORMATION FROM IT TO OTHERS NOR TO MAKE ANY USE OF IT THAT IS OR MAY BE INJURIOUS TO **CHENTRONICS**. FOR MORE INFORMATION PLEASE CONTACT **CHENTRONICS** AT +1.607.334.5531.

IVN / TRULIGHT

GAS PILOT IGNITION AND FLAME DETECTION SYSTEM Installation and Operation Manual



IVN 04001000



IVN 04000900



TRULIGHT 04001090



TRULIGHT 04000990

**KEEP THIS MANUAL IN A SAFE PLACE
 FOR FUTURE REFERENCE**

READ THIS MANUAL BEFORE USING THIS PRODUCT. FAILURE TO FOLLOW THE INSTRUCTIONS AND SAFETY PRECAUTIONS IN THIS MANUAL CAN RESULT IN SERIOUS INJURY OR DEATH OR DAMAGE TO EQUIPMENT.

RELATED DOCUMENT – MUST COMPLY WITH SCHEDULE DOCUMENT(S):

CERT-IVN MNL

FOR A LIST OF RELEVANT PATENTS AND TRADEMARKS PLEASE SEE CHENTRONICS.COM/LEGAL-NOTICES

ISO 9001 CERTIFIED

IVN/TRULIGHT MANUAL

PAGE 1 OF 28

DRAWN BY: AR
ON: 05/14/21

LAST REV BY: XXX
ON: x/y/z

DCO No.
14194

DWG. No. MNL-IVN

REV. C



TOLERANCE NOTES

FABRICATED TOLERANCES

≥ 2 ft (610 mm) ± 0.250 in (6.4 mm)
< 2ft (610 mm) ± 0.125 in (3.2 mm)

MACHINED TOLERANCES

± 0.050 DECIMAL DIM (1 PLACE)
± 0.010 DECIMAL DIM (2 PLACES)
± 0.005 DECIMAL DIM (3 PLACES)

MNL-IVN

THIS DRAWING OWNED BY **CHENTRONICS**. IT IS CONDITIONALLY LOANED AND IS TO BE RETURNED UPON REQUEST. THE BORROWER BY RECEIVING IT HAS AGREED NOT TO REPRODUCE NOR COPY IT IN WHOLE OR IN PART NOR TO FURNISH INFORMATION FROM IT TO OTHERS NOR TO MAKE ANY USE OF IT THAT IS OR MAY BE INJURIOUS TO **CHENTRONICS**. FOR MORE INFORMATION PLEASE CONTACT **CHENTRONICS** AT +1.607.334.5531.

1.0 Important Safety Information



Read All Instructions before Using Equipment



The instructions provided in this manual have been prepared to serve as a general guide. It is intended for use by qualified personnel with knowledge of equipment of this type. It is not intended to cover all possible variations in equipment or to provide for specific operating problems which may arise.

You are responsible for adhering to all warnings or cautions provided in this Manual.

In addition to any general safety measures provided in this Manual, you must comply with all current national, state, local and company safety regulations at all times.

Safety Symbols used in this manual comply with ISO 3864.

THESE SYMBOLS ARE USED TO ALERT YOU TO POTENTIAL PERSONAL INJURY HAZARDS.

OBEY ALL SAFETY MESSAGES THAT FOLLOW THESE SYMBOLS TO AVOID POSSIBLE INJURY OR DEATH.



Indicates a hazard with a high level of risk which, if not avoided will result in death or serious injury.



Indicates a hazard with a medium level of risk which, if not avoided could result in death or serious injury.



Indicates a hazard with a low level of risk which, if not avoided will result in minor or moderate injury.

RELATED DOCUMENT – MUST COMPLY WITH SCHEDULE DOCUMENT(S):

CERT-IVN MNL

FOR A LIST OF RELEVANT PATENTS AND TRADEMARKS PLEASE SEE CHENTRONICS.COM/LEGAL-NOTICES

ISO 9001 CERTIFIED

IVN/TRULIGHT MANUAL

PAGE 2 OF 28

DRAWN BY: AR
ON: 05/14/21

LAST REV BY: XXX
ON: x/y/z

DCO No.
14194

DWG. No. **MNL-IVN**

REV. **C**



TOLERANCE NOTES

FABRICATED TOLERANCES

≥ 2 ft (610 mm) ± 0.250 in (6.4 mm)
< 2ft (610 mm) ± 0.125 in (3.2 mm)

MACHINED TOLERANCES

± 0.050 DECIMAL DIM (1 PLACE)
± 0.010 DECIMAL DIM (2 PLACES)
± 0.005 DECIMAL DIM (3 PLACES)

MNL-IVN

THIS DRAWING OWNED BY **CHENTRONICS**. IT IS CONDITIONALLY LOANED AND IS TO BE RETURNED UPON REQUEST. THE BORROWER BY RECEIVING IT HAS AGREED NOT TO REPRODUCE NOR COPY IT IN WHOLE OR IN PART NOR TO FURNISH INFORMATION FROM IT TO OTHERS NOR TO MAKE ANY USE OF IT THAT IS OR MAY BE INJURIOUS TO **CHENTRONICS**. FOR MORE INFORMATION PLEASE CONTACT **CHENTRONICS** AT +1.607.334.5531.



HAZARDOUS VOLTAGE

The equipment contains a High Energy Ignition System which contains **DANGEROUS AND POTENTIALLY LETHAL VOLTAGE**. To avoid risk of serious injury from electric shock, always follow the safety precautions listed below:

Disconnect power before servicing the equipment.

Ensure the equipment is appropriately bonded to earth before use. See Section 0 regarding equipment earth bond locations.

Do not join or separate any connection to the equipment when the equipment is energized.

Do not apply power to the equipment without an igniter attached or the igniter port appropriately capped.

Keep the igniter firing end away from all personnel and flammable material.

Do not apply power to the equipment without a flame rod harness attached or without the flame rod output appropriately capped.

Do not apply power to the equipment unless the flame rod harness output wire is appropriately terminated in the pilot assembly (04001000 / 04001090 / 04000900 / 04000990 PNs).

Keep the energized flame rod away from all personnel and flammable material.

The equipment must be installed and serviced by qualified personnel in accordance with applicable local and national codes, standards, and ordinances.

The equipment is not field-repairable. Do not attempt to disassemble or repair the equipment.

RELATED DOCUMENT – MUST COMPLY WITH SCHEDULE DOCUMENT(S):

CERT-IVN MNL

FOR A LIST OF RELEVANT PATENTS AND TRADEMARKS PLEASE SEE CHENTRONICS.COM/LEGAL-NOTICES

ISO 9001 CERTIFIED

IVN/TRULIGHT MANUAL

PAGE 3 OF 28

DRAWN BY:
AR

ON:
05/14/21

LAST REV BY:
XXX

ON:
x/y/z

DCO No.
14194

DWG. No. MNL-IVN

REV. C



TOLERANCE NOTES**FABRICATED TOLERANCES**

≥ 2 ft (610 mm) ± 0.250 in (6.4 mm)
 < 2ft (610 mm) ± 0.125 in (3.2 mm)

MACHINED TOLERANCES

± 0.050 DECIMAL DIM (1 PLACE)
 ± 0.010 DECIMAL DIM (2 PLACES)
 ± 0.005 DECIMAL DIM (3 PLACES)

MNL-IVN

THIS DRAWING OWNED BY **CHENTRONICS**. IT IS CONDITIONALLY LOANED AND IS TO BE RETURNED UPON REQUEST. THE BORROWER BY RECEIVING IT HAS AGREED NOT TO REPRODUCE NOR COPY IT IN WHOLE OR IN PART NOR TO FURNISH INFORMATION FROM IT TO OTHERS NOR TO MAKE ANY USE OF IT THAT IS OR MAY BE INJURIOUS TO **CHENTRONICS**. FOR MORE INFORMATION PLEASE CONTACT **CHENTRONICS** AT +1.607.334.5531.



EXPLOSION HAZARD

Do not connect, disconnect, or service the equipment if an Explosive Atmosphere may be present.

The equipment must be installed and serviced by qualified personnel in accordance with applicable local and national codes, standards, and ordinances.

The equipment's enclosure may not be modified.

The equipment is not user/field repairable and must be returned to the manufacturer for repair in the event of an equipment malfunction.

Do not disassemble the internal electrical assembly. Improper reassembly of internal components could compromise the equipment's suitability for Class 1 Division 2 / Zone 2.

Substitution of components may impair suitability for Class 1 Division 2 / Zone 2.



Lisez toutes les instructions avant d'utiliser l'équipement



Les instructions fournies dans ce manuel ont été préparées pour servir de guide général. Il est destiné à être utilisé par du personnel qualifié connaissant l'équipement de ce type. Il n'est pas destiné à couvrir toutes les variations possibles d'équipement ni à régler les problèmes de fonctionnement spécifiques qui peuvent survenir.

Vous êtes responsable du respect de tous les avertissements ou mises en garde fournis dans ce manuel.

En plus des mesures de sécurité générales fournies dans ce manuel, vous devez respecter à tout moment toutes les réglementations de sécurité nationales, nationales, locales et de l'entreprise.

RELATED DOCUMENT – MUST COMPLY WITH SCHEDULE DOCUMENT(S):

CERT-IVN MNL

FOR A LIST OF RELEVANT PATENTS
 AND TRADEMARKS PLEASE SEE
 CHENTRONICS.COM/LEGAL-NOTICES

ISO 9001 CERTIFIED

DRAWN BY: AR
ON: 05/14/21

LAST REV BY: XXX
ON: x/y/z

DCO No.
14194

DWG. No. MNL-IVN

REV. C

PAGE 4 OF 28

TOLERANCE NOTES**FABRICATED TOLERANCES**

≥ 2 ft (610 mm) ± 0.250 in (6.4 mm)
 < 2ft (610 mm) ± 0.125 in (3.2 mm)

MACHINED TOLERANCES

± 0.050 DECIMAL DIM (1 PLACE)
 ± 0.010 DECIMAL DIM (2 PLACES)
 ± 0.005 DECIMAL DIM (3 PLACES)

MNL-IVN

THIS DRAWING OWNED BY **CHENTRONICS**. IT IS CONDITIONALLY LOANED AND IS TO BE RETURNED UPON REQUEST. THE BORROWER BY RECEIVING IT HAS AGREED NOT TO REPRODUCE NOR COPY IT IN WHOLE OR IN PART NOR TO FURNISH INFORMATION FROM IT TO OTHERS NOR TO MAKE ANY USE OF IT THAT IS OR MAY BE INJURIOUS TO **CHENTRONICS**. FOR MORE INFORMATION PLEASE CONTACT **CHENTRONICS** AT +1.607.334.5531.

Les symboles de sécurité utilisés dans ce manuel sont conformes à la norme ISO 3864.

CES SYMBOLES SONT UTILISÉS POUR VOUS AVERTIR DES RISQUES DE BLESSURES POTENTIELS.

RESPECTEZ TOUS LES MESSAGES DE SÉCURITÉ QUI SUIVENT CES SYMBOLES POUR ÉVITER LES BLESSURES POTENTIELLES OU LA MORT.



Indique un danger avec un niveau élevé de risque qui, s'il n'est pas évité, entraînera la mort ou des blessures graves.



Indique un danger avec un niveau de risque moyen qui, s'il n'est pas évité, pourrait entraîner la mort ou des blessures graves.



Indique un danger avec un niveau de risque bas qui, s'il n'est pas évité, entraînera des blessures mineures ou modérées.



TENSION DANGEREUSE

L'équipement contient un système d'allumage à haute énergie qui contient une tension dangereuse et potentiellement létale. Pour éviter tout risque de blessure grave par électrocution, suivez toujours les précautions de sécurité énumérées ci-dessous:

Débranchez l'alimentation avant de réparer l'équipement.

Assurez-vous que l'équipement est correctement relié à la terre avant utilisation. Voir la section 5.6 concernant l'emplacement des liaisons de terre des équipements

Ne connectez ou ne séparez aucune connexion à l'équipement lorsque celui-ci est sous tension

N'appliquez pas d'alimentation à l'équipement sans un allumeur connecté ou le port de l'allumeur correctement bouché

Gardez le bout de l'allumeur éloigné du personnel et des matières inflammables

Ne mettez pas l'équipement sous tension sans un harnais à tige de flamme ou sans sortie de la tige à flamme correctement obturée

Ne mettez pas l'équipement sous tension, sauf si le fil de sortie du faisceau de la tige de la flamme est correctement raccordé à la veilleuse (modèles 04001000 / 04001090 / 04000900 / 04000990)

RELATED DOCUMENT – MUST COMPLY WITH SCHEDULE DOCUMENT(S):

CERT-IVN MNL

FOR A LIST OF RELEVANT PATENTS AND TRADEMARKS PLEASE SEE CHENTRONICS.COM/LEGAL-NOTICES

ISO 9001 CERTIFIED

IVN/TRULIGHT MANUAL

PAGE 5 OF 28

DRAWN BY: AR
ON: 05/14/21

LAST REV BY: XXX
ON: x/y/z

DCO No.
14194

DWG. No. MNL-IVN

REV. C

TOLERANCE NOTES**FABRICATED TOLERANCES**

≥ 2 ft (610 mm) ± 0.250 in (6.4 mm)
 < 2ft (610 mm) ± 0.125 in (3.2 mm)

MACHINED TOLERANCES

± 0.050 DECIMAL DIM (1 PLACE)
 ± 0.010 DECIMAL DIM (2 PLACES)
 ± 0.005 DECIMAL DIM (3 PLACES)

MNL-IVN

THIS DRAWING OWNED BY **CHENTRONICS**. IT IS CONDITIONALLY LOANED AND IS TO BE RETURNED UPON REQUEST. THE BORROWER BY RECEIVING IT HAS AGREED NOT TO REPRODUCE NOR COPY IT IN WHOLE OR IN PART NOR TO FURNISH INFORMATION FROM IT TO OTHERS NOR TO MAKE ANY USE OF IT THAT IS OR MAY BE INJURIOUS TO **CHENTRONICS**. FOR MORE INFORMATION PLEASE CONTACT **CHENTRONICS** AT +1.607.334.5531.

Gardez la tige de flamme sous tension loin de tout personnel et de tout produit inflammable

L'équipement doit être installé et entretenu par du personnel qualifié conformément aux codes, normes et ordonnances locales et nationales applicables

L'équipement n'est pas réparable sur le terrain. N'essayez pas de démonter ou de réparer l'équipement



DANGER
RISQUE D'EXPLOSION



Ne connectez pas, ne débranchez pas et ne réparez pas l'équipement si une atmosphère explosive peut être présent

L'équipement doit être installé et entretenu par du personnel qualifié conformément aux codes, normes et ordonnances locales et nationales applicables

Le boîtier de l'équipement ne peut pas être modifié

L'équipement n'est pas réparable par l'utilisateur / sur le terrain et doit être retourné au fabricant pour réparation en cas de dysfonctionnement de l'équipement.

Ne démontez pas l'ensemble électrique interne. Un réassemblage incorrect des composants internes pourrait compromettre la compatibilité de l'équipement en classe 1, division 2 / zone 2

La substitution de composants peut compromettre l'adéquation à la classe 1, division 2 / zone 2

2.0 Definitions

Spark – An electric current arc.

High Energy Ignition – Electric spark ignition system utilizing high energy sparks for direct ignition of hydrocarbon fuels such as gas, diesel, or #6 oil.

High Energy Exciter – An electronic device that stores electric charge and releases it cyclically in abrupt bursts to an igniter to create high power sparks.

RELATED DOCUMENT – MUST COMPLY WITH SCHEDULE DOCUMENT(S):

CERT-IVN MNL

FOR A LIST OF RELEVANT PATENTS
 AND TRADEMARKS PLEASE SEE
 CHENTRONICS.COM/LEGAL-NOTICES

ISO 9001 CERTIFIED

DRAWN BY: AR
ON: 05/14/21

LAST REV BY: XXX
ON: x/y/z

DCO No.
14194

DWG. No. MNL-IVN

REV. C

IVN/TRULIGHT MANUAL

PAGE 6 OF 28

TOLERANCE NOTES

FABRICATED TOLERANCES

≥ 2 ft (610 mm) ± 0.250 in (6.4 mm)
< 2ft (610 mm) ± 0.125 in (3.2 mm)

MACHINED TOLERANCES

± 0.050 DECIMAL DIM (1 PLACE)
± 0.010 DECIMAL DIM (2 PLACES)
± 0.005 DECIMAL DIM (3 PLACES)

MNL-IVN

THIS DRAWING OWNED BY **CHENTRONICS**. IT IS CONDITIONALLY LOANED AND IS TO BE RETURNED UPON REQUEST. THE BORROWER BY RECEIVING IT HAS AGREED NOT TO REPRODUCE NOR COPY IT IN WHOLE OR IN PART NOR TO FURNISH INFORMATION FROM IT TO OTHERS NOR TO MAKE ANY USE OF IT THAT IS OR MAY BE INJURIOUS TO **CHENTRONICS**. FOR MORE INFORMATION PLEASE CONTACT **CHENTRONICS** AT +1.607.334.5531.

Flame Rectification Detector – An electronic device that detects the rectified current property created by placing two disproportionately sized electrodes in a flame with an AC excitation voltage applied between them.

Flame Rod – Smaller of two electrodes in a Flame Rectification Detector system.

3.0 Chentronics High Energy Ignition Systems

Chentronics High Energy Ignition (HEI) systems directly ignite burner fuels by providing short time duration (impulse), high current electrical arcs commonly referred to as *sparks*. These sparks are generated by abruptly releasing electrical energy (charge) stored in large capacitors. The energy is released through an igniter driver circuit called a *pulse forming network* to specialized high energy igniters. The result is a high-power spark with increased ability to ignite fuels.

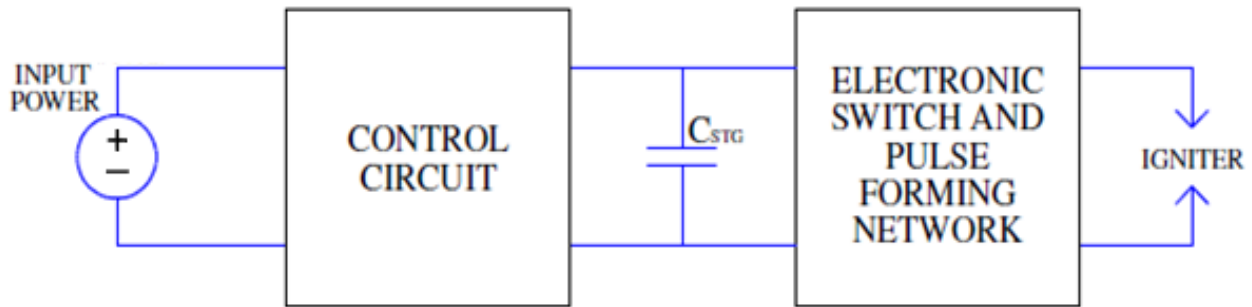

Figure 1: High Energy Exciter basic schematic



Figure 2: Igniter firing in water

NOTE: Firing igniters submerged in water will cause them to excessively wear and reach end of life very quickly

RELATED DOCUMENT – MUST COMPLY WITH SCHEDULE DOCUMENT(S):

CERT-IVN MNL

FOR A LIST OF RELEVANT PATENTS AND TRADEMARKS PLEASE SEE CHENTRONICS.COM/LEGAL-NOTICES

ISO 9001 CERTIFIED

IVN/TRULIGHT MANUAL

PAGE 7 OF 28

DRAWN BY: AR
ON: 05/14/21

LAST REV BY: XXX
ON: x/y/z

DCO No.
14194

DWG. No. MNL-IVN

REV. C



TOLERANCE NOTES

FABRICATED TOLERANCES

≥ 2 ft (610 mm) ± 0.250 in (6.4 mm)
< 2ft (610 mm) ± 0.125 in (3.2 mm)

MACHINED TOLERANCES

± 0.050 DECIMAL DIM (1 PLACE)
± 0.010 DECIMAL DIM (2 PLACES)
± 0.005 DECIMAL DIM (3 PLACES)

MNL-IVN

THIS DRAWING OWNED BY **CHENTRONICS**. IT IS CONDITIONALLY LOANED AND IS TO BE RETURNED UPON REQUEST. THE BORROWER BY RECEIVING IT HAS AGREED NOT TO REPRODUCE NOR COPY IT IN WHOLE OR IN PART NOR TO FURNISH INFORMATION FROM IT TO OTHERS NOR TO MAKE ANY USE OF IT THAT IS OR MAY BE INJURIOUS TO **CHENTRONICS**. FOR MORE INFORMATION PLEASE CONTACT **CHENTRONICS** AT +1.607.334.5531.

4.0 System Specifications

4.1 Description of Equipment

The Chentronics IVN / TRULIGHT gas pilot ignition and flame detection system is comprised of an electronic high energy ignition system and flame rod rectified flame ionization current type flame detector integrated into one small convenient electronics package. Using the unique triaxial igniter/flame rod design, the system quickly ignites pilot burners in the wet and dirty startup conditions while simultaneously detecting and affirming the presence of the resulting burner flame. The system is designed for direct to pilot mounting via its output rod. An optionally configured PN allows connection to the traditional flame rod of virtually any pilot using a flame rod harness. Output rods and igniters of various lengths are available for this integrated system. For associated system component part numbers see Section 7.0.

The IVN / TruLight systems are available in two configurations:

INTEGRATED IGNITION AND FLAME ROD

Configured to connect to the Chentronics triaxial combination igniter/flame rod for single probe ignition and flame detection. For associated system component part numbers see Section 7.0.



■ IVN 04001000



■ TRULIGHT 04001090

RELATED DOCUMENT – MUST COMPLY WITH SCHEDULE DOCUMENT(S):

CERT-IVN MNL

FOR A LIST OF RELEVANT PATENTS AND TRADEMARKS PLEASE SEE CHENTRONICS.COM/LEGAL-NOTICES

ISO 9001 CERTIFIED

IVN/TRULIGHT MANUAL

PAGE 8 OF 28

DRAWN BY: AR
ON: 05/14/21

LAST REV BY: XXX
ON: x/y/z

DCO No.
14194

DWG. No. MNL-IVN

REV. C



TOLERANCE NOTES

FABRICATED TOLERANCES

≥ 2 ft (610 mm) ± 0.250 in (6.4 mm)
< 2ft (610 mm) ± 0.125 in (3.2 mm)

MACHINED TOLERANCES

± 0.050 DECIMAL DIM (1 PLACE)
± 0.010 DECIMAL DIM (2 PLACES)
± 0.005 DECIMAL DIM (3 PLACES)

MNL-IVN

THIS DRAWING OWNED BY **CHENTRONICS**. IT IS CONDITIONALLY LOANED AND IS TO BE RETURNED UPON REQUEST. THE BORROWER BY RECEIVING IT HAS AGREED NOT TO REPRODUCE NOR COPY IT IN WHOLE OR IN PART NOR TO FURNISH INFORMATION FROM IT TO OTHERS NOR TO MAKE ANY USE OF IT THAT IS OR MAY BE INJURIOUS TO **CHENTRONICS**. FOR MORE INFORMATION PLEASE CONTACT **CHENTRONICS** AT +1.607.334.5531.

SEPARATE IGNITION AND FLAME ROD

Configured to connect to Chentronics 12 series igniters and separate flame rod setups. For associated system component part numbers see Section 7.0.

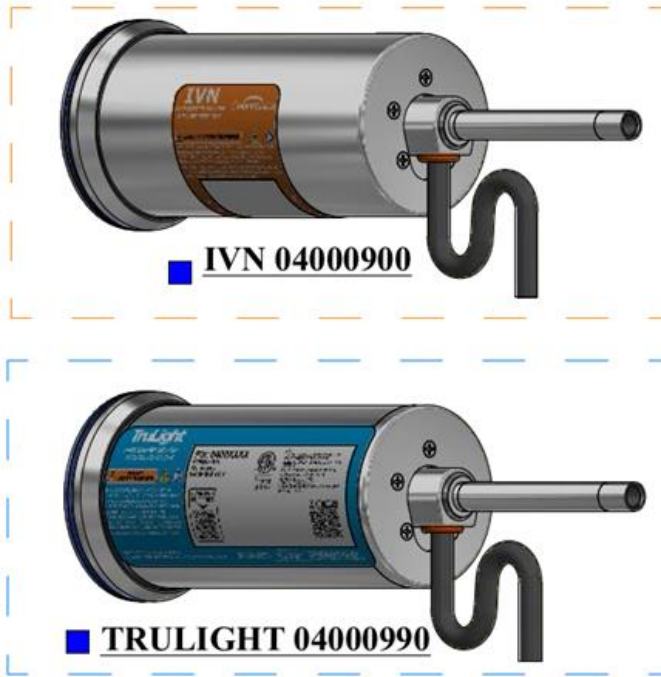

4.2 Description of Equipment Protective System

A stainless-steel IP-rated enclosure houses the electronics assembly. The system utilizes an increased safety / non-arcing / non-incendiary type protection method. See Section 4.4 for equipment certification and marking information.

4.3 Equipment Conditions of Use

The IVN / TRULIGHT system equipment is subject to the following conditions of use and limitations:

1. The equipment should only be used in an area that has low risk of impact.
2. The equipment should be used in area that is free from falling debris.
3. The equipment should be placed in an area that do not have any mechanical hazard.
4. The equipment shall not be subjected to human abuse.

RELATED DOCUMENT – MUST COMPLY WITH SCHEDULE DOCUMENT(S):

CERT-IVN MNL

FOR A LIST OF RELEVANT PATENTS AND TRADEMARKS PLEASE SEE CHENTRONICS.COM/LEGAL-NOTICES

ISO 9001 CERTIFIED

IVN/TRULIGHT MANUAL

PAGE 9 OF 28

DRAWN BY: AR
ON: 05/14/21

LAST REV BY: XXX
ON: x/y/z

DCO No.
14194

DWG. No. MNL-IVN

REV. C



TOLERANCE NOTES

FABRICATED TOLERANCES

≥ 2 ft (610 mm) ± 0.250 in (6.4 mm)
 < 2ft (610 mm) ± 0.125 in (3.2 mm)

MACHINED TOLERANCES

± 0.050 DECIMAL DIM (1 PLACE)
 ± 0.010 DECIMAL DIM (2 PLACES)
 ± 0.005 DECIMAL DIM (3 PLACES)

MNL-IVN

THIS DRAWING OWNED BY **CHENTRONICS**. IT IS CONDITIONALLY LOANED AND IS TO BE RETURNED UPON REQUEST. THE BORROWER BY RECEIVING IT HAS AGREED NOT TO REPRODUCE NOR COPY IT IN WHOLE OR IN PART NOR TO FURNISH INFORMATION FROM IT TO OTHERS NOR TO MAKE ANY USE OF IT THAT IS OR MAY BE INJURIOUS TO **CHENTRONICS**. FOR MORE INFORMATION PLEASE CONTACT **CHENTRONICS** AT +1.607.334.5531.

4.4 Electrical Area Classification and Safety Markings

The IVN / TRULIGHT system has been assessed to and complies with the following safety and hazardous location standards:

APPROVED CERTIFICATIONS



USA: CLASS I DIVISION 2 GROUPS ABCD T4
 CLASS I ZONE 2 GROUP IIC T4
 CLASS I ZONE 2 AEx ec nC IIC Gc T4 IP64

CANADA: CLASS I DIVISION 2 GROUPS ABCD T4
 CLASS I ZONE 2 GROUP IIC T4
 Ex ec nC IIC Gc T4 IP64

SPECIAL CONDITION: X
 AMBIENT TEMPERATURE: -45°C to +85°C
 TYPE 4X SIL3



Ex ec nC IIC T4 Gc IP64
 -45°C to +85°C
 IECEX ETL 19.0008X



II 3 G Ex ec nC IIC T4 Gc IP64
 ITS19ATEX14543X
 -45°C ≤ Ta ≤ 85°C



2Ex nA nC IIC T4 Gc X
 EAЭC N RU Д-US.PA01.B.20059/21



Segurança
 INMETRO OCP 0034
 Ex ec nC IIC T4 Gc IP64
 (-40°C ≤ Tamb ≤ 85°C)
 NCC 20.0088X

TESTED PER THE FOLLOWING STANDARDS:
 USA» UL50E, UL 60730-1, UL 60730-2-5, UL 121201, ANSI Z21.20, UL 60079-0, UL 60079-7, UL 60079-15
 CANADA» CSA C22.2#213, CSA E60730-1, CSA C22.2#60730-2-5, CSA C22.2#60079-0, CSA C22.2#60079-7, CSA C22.2#60079-15
 IEC» IEC 60079-0, IEC 60079-7, IEC 60079-15
 EUROPE» EN 60730-1, EN 60730-2-5, EN 60079-0, EN 60079-7, EN 60079-15, EN 298
 BRAZIL» ABNT NBR IEC 60079-0, ABNT NBR IEC 60079-7, ABNT NBR IEC 60079-15
 RUSSIA» TP TC 012/2011, GOCT 31610.0-2014, GOCT 31610.15-2014

Application:	Gas pilot ignition and flame detection system
Input Power:	24VDC Nominal, 2A MAX
Exciter Type:	High Energy Ignition
Exciter Duty Cycle:	30sec ON / 2min OFF ¹
Exciter Spark Command:	INPUT - close wire A to C with relay contact to start exciter
Exciter Spark Diagnostic Signal:	OUTPUT – Dry Relay Contact Set, 60V, 0.5A
Exciter Power:	2J per Spark at 5 Sparks per Second Nominal
Flame Detector Type:	For Rectifying Flame Rod type installations
Flame Detector Duty:	Continuous
Flame Detector Relay:	OUTPUT – Dry Relay Contact Set, 24VDC, 1A 125VAC, 0.50A
Flame Detector FDRT:	0.7 seconds MAX
Operating Temperature Limits:	-45°C ² to 85°C
Storage Temperature Limits:	-55°C to 100°C
Humidity:	0 to 100% condensing
Enclosure:	Stainless-Steel, TYPE 4X, IP64
Electronics Assembly Weight:	Approximately 4lb
04001000 / PN 04001090 Dimensions:	Approximately 3.4 Dia x 8 inches
04000900 / PN 04000990 Dimensions:	Approximately 3.4 Dia x 12 inches

RELATED DOCUMENT – MUST COMPLY WITH SCHEDULE DOCUMENT(S):

CERT-IVN MNL

FOR A LIST OF RELEVANT PATENTS AND TRADEMARKS PLEASE SEE CHENTRONICS.COM/LEGAL-NOTICES

ISO 9001 CERTIFIED

IVN/TRULIGHT MANUAL

PAGE 10 OF 28

DRAWN BY: AR
ON: 05/14/21

LAST REV BY: XXX
ON: x/y/z

DCO No.
14194

DWG. No. MNL-IVN

REV. C



TOLERANCE NOTES

FABRICATED TOLERANCES

≥ 2 ft (610 mm) ± 0.250 in (6.4 mm)
< 2ft (610 mm) ± 0.125 in (3.2 mm)

MACHINED TOLERANCES

± 0.050 DECIMAL DIM (1 PLACE)
± 0.010 DECIMAL DIM (2 PLACES)
± 0.005 DECIMAL DIM (3 PLACES)

MNL-IVN

THIS DRAWING OWNED BY **CHENTRONICS**. IT IS CONDITIONALLY LOANED AND IS TO BE RETURNED UPON REQUEST. THE BORROWER BY RECEIVING IT HAS AGREED NOT TO REPRODUCE NOR COPY IT IN WHOLE OR IN PART NOR TO FURNISH INFORMATION FROM IT TO OTHERS NOR TO MAKE ANY USE OF IT THAT IS OR MAY BE INJURIOUS TO **CHENTRONICS**. FOR MORE INFORMATION PLEASE CONTACT **CHENTRONICS** AT +1.607.334.5531.

¹**Note:** Exceeding the exciter duty cycle limit can cause the exciter to fail.

²**Note:** The equipment contains an onboard heater. The heater becomes active when the internal temperature of the electronics is less than -15°C. When the electronics are cold started at an ambient temperature less than -25°C, allow 15 minutes of power-on operation before use so the heater may increase the internal temperature of the electronics. When the temperature of the internal electronics is below -25°C, the unit will be in Over/Under Temperature Warning mode and the flame detector will not operate. See Section 6.6 for indicator operating in various equipment modes.



EXPLOSION HAZARD

Do not exceed equipment operating specifications. Operating the system outside its prescribed specifications could compromise its hazardous area protective systems and can result in serious injury or death or damage to equipment.



RISQUE D'EXPLOSION

Ne pas dépasser les spécifications de fonctionnement de l'équipement. Un fonctionnement du système en dehors des spécifications prescrites pourrait compromettre ses systèmes de protection pour zone dangereuse et peut entraîner des blessures graves ou la mort ou des dommages matériels.

RELATED DOCUMENT – MUST COMPLY WITH SCHEDULE DOCUMENT(S):

CERT-IVN MNL

FOR A LIST OF RELEVANT PATENTS AND TRADEMARKS PLEASE SEE CHENTRONICS.COM/LEGAL-NOTICES

ISO 9001 CERTIFIED

IVN/TRULIGHT MANUAL

PAGE 11 OF 28

DRAWN BY: AR
ON: 05/14/21

LAST REV BY: XXX
ON: x/y/z

DCO No.
14194

DWG. No. MNL-IVN

REV. C



TOLERANCE NOTES

FABRICATED TOLERANCES

≥ 2 ft (610 mm) ± 0.250 in (6.4 mm)
< 2ft (610 mm) ± 0.125 in (3.2 mm)

MACHINED TOLERANCES

± 0.050 DECIMAL DIM (1 PLACE)
± 0.010 DECIMAL DIM (2 PLACES)
± 0.005 DECIMAL DIM (3 PLACES)

MNL-IVN

THIS DRAWING OWNED BY **CHENTRONICS**. IT IS CONDITIONALLY LOANED AND IS TO BE RETURNED UPON REQUEST. THE BORROWER BY RECEIVING IT HAS AGREED NOT TO REPRODUCE NOR COPY IT IN WHOLE OR IN PART NOR TO FURNISH INFORMATION FROM IT TO OTHERS NOR TO MAKE ANY USE OF IT THAT IS OR MAY BE INJURIOUS TO **CHENTRONICS**. FOR MORE INFORMATION PLEASE CONTACT **CHENTRONICS** AT +1.607.334.5531.

5.0 Assembly and Installation Instructions

5.1 PN 04001000 / PN 04001090 Assembly

The IVN / TRULIGHT system PN 04001000 / PN 04001090 is designed to be used in conjunction with the Chentronics Triaxial combination igniter/flame rod lance assembly. The lance assembly can ignite a pilot while simultaneously detecting the resulting flame. The equipment has been designed to work best with the system components listed in Section 7.0.

The triaxial lance assembly is comprised of two components: an igniter with integrated flame rod and a Base Rod. See Figure 3 and Figure 4 illustrating these components.



Figure 3: Igniter with integrated flame rod.



Figure 4: Triaxial Base Rod.

To install the Igniter into the Triaxial Base Rod, insert the igniter male connector into the female socket connector on the Base Rod, then tighten clockwise until snug. See Figure 5 for illustration of component installation.



Figure 5: Igniter installation into Base Rod.

RELATED DOCUMENT – MUST COMPLY WITH SCHEDULE DOCUMENT(S):

CERT-IVN MNL

FOR A LIST OF RELEVANT PATENTS AND TRADEMARKS PLEASE SEE CHENTRONICS.COM/LEGAL-NOTICES

ISO 9001 CERTIFIED

IVN/TRULIGHT MANUAL

PAGE 12 OF 28

DRAWN BY: AR
ON: 05/14/21

LAST REV BY: XXX
ON: x/y/z

DCO No.
14194

DWG. No. **MNL-IVN**

REV. **C**



TOLERANCE NOTES

FABRICATED TOLERANCES

≥ 2 ft (610 mm) ± 0.250 in (6.4 mm)
 < 2ft (610 mm) ± 0.125 in (3.2 mm)

MACHINED TOLERANCES

± 0.050 DECIMAL DIM (1 PLACE)
 ± 0.010 DECIMAL DIM (2 PLACES)
 ± 0.005 DECIMAL DIM (3 PLACES)

MNL-IVN

THIS DRAWING OWNED BY **CHENTRONICS**. IT IS CONDITIONALLY LOANED AND IS TO BE RETURNED UPON REQUEST. THE BORROWER BY RECEIVING IT HAS AGREED NOT TO REPRODUCE NOR COPY IT IN WHOLE OR IN PART NOR TO FURNISH INFORMATION FROM IT TO OTHERS NOR TO MAKE ANY USE OF IT THAT IS OR MAY BE INJURIOUS TO **CHENTRONICS**. FOR MORE INFORMATION PLEASE CONTACT **CHENTRONICS** AT +1.607.334.5531.

To install the Triaxial Base Rod into the electronics, align the connectors, insert until seated as shown, then tighten the backing nut clockwise until it bottoms out against the exciter. See Figure 6 and Figure 7 for illustration of component installation.

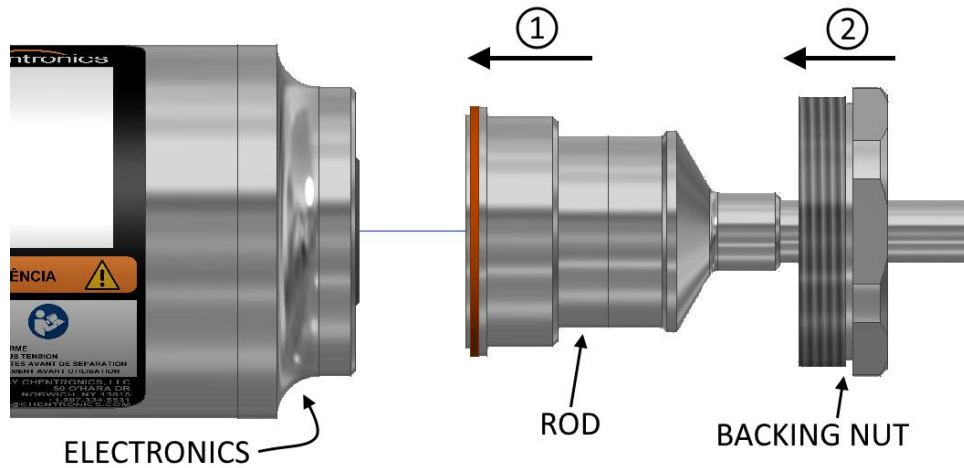

Figure 6: Igniter installation.

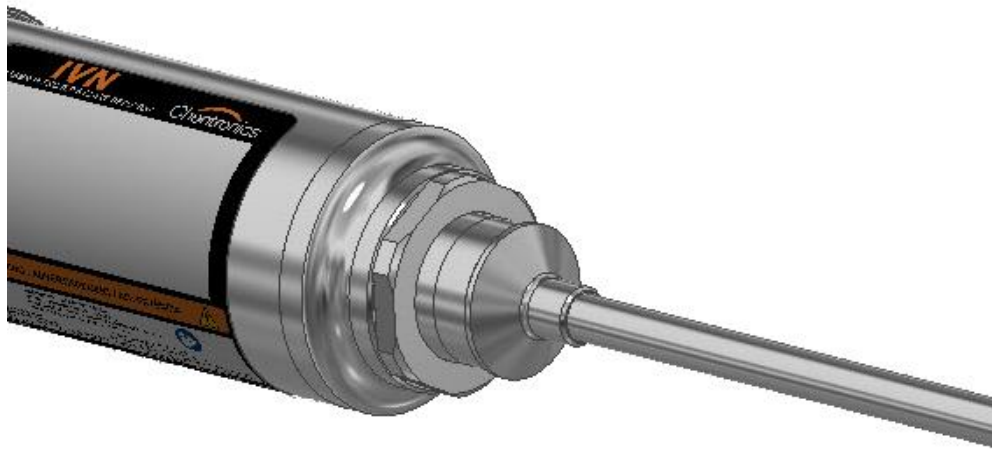

Figure 7: Base Rod installed.

The triaxial lance assembly should be installed into the pilot burner with its terminating spark tip end in an electrically unclassified area (inside the burner). Refer to the pilot burner manufacturer’s instructions before installing equipment on a pilot burner system.

RELATED DOCUMENT – MUST COMPLY WITH SCHEDULE DOCUMENT(S):

CERT-IVN MNL

FOR A LIST OF RELEVANT PATENTS AND TRADEMARKS PLEASE SEE CHENTRONICS.COM/LEGAL-NOTICES

ISO 9001 CERTIFIED

IVN/TRULIGHT MANUAL

PAGE 13 OF 28

DRAWN BY: AR
ON: 05/14/21

LAST REV BY: XXX
ON: x/y/z

DCO No.
14194

DWG. No. MNL-IVN

REV. C



TOLERANCE NOTES

FABRICATED TOLERANCES

≥ 2 ft (610 mm) ± 0.250 in (6.4 mm)
 < 2ft (610 mm) ± 0.125 in (3.2 mm)

MACHINED TOLERANCES

± 0.050 DECIMAL DIM (1 PLACE)
 ± 0.010 DECIMAL DIM (2 PLACES)
 ± 0.005 DECIMAL DIM (3 PLACES)

MNL-IVN

THIS DRAWING OWNED BY **CHENTRONICS**. IT IS CONDITIONALLY LOANED AND IS TO BE RETURNED UPON REQUEST. THE BORROWER BY RECEIVING IT HAS AGREED NOT TO REPRODUCE NOR COPY IT IN WHOLE OR IN PART NOR TO FURNISH INFORMATION FROM IT TO OTHERS NOR TO MAKE ANY USE OF IT THAT IS OR MAY BE INJURIOUS TO **CHENTRONICS**. FOR MORE INFORMATION PLEASE CONTACT **CHENTRONICS** AT +1.607.334.5531.

5.2 PN 04000900 / PN 04000990 Assembly

The IVN / TRULIGHT system PN 04000900 / PN 04000990 utilizes a Chentronics 12 series igniter and is designed to drive a separate flame rod assembly for traditional separate igniter/flame rod lance installations. The equipment has been designed to work best with the system components listed in Section 7.0.

To install the igniter into the electronics, insert the Igniter male connector into the female socket connector on the Electronics, then tighten clockwise until snug. See Figure 8 for illustration of component installation.

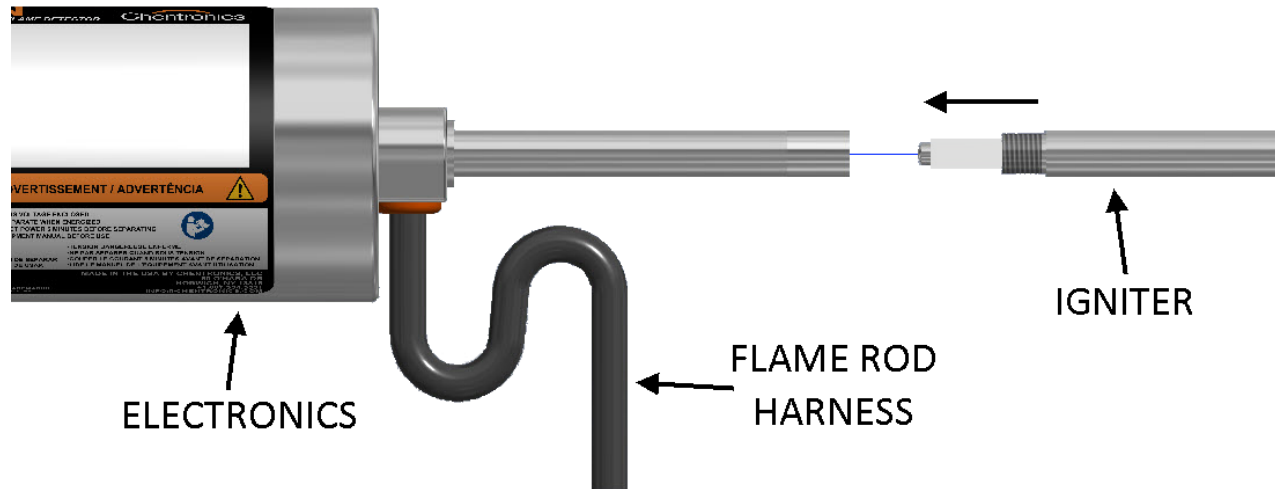

Figure 8: 12 Series igniter installation.

The igniter should be installed into the pilot burner with its terminating spark tip end in an electrically unclassified area (inside the burner). The flame rod harness should be terminated appropriately to the pilot's flame rod assembly using fittings and terminal enclosures as required in accordance with the installation. Refer to the pilot burner manufacturer's instructions before installing equipment on a pilot burner system.

5.3 Power/Control Cable Installation

The IVN / TRULIGHT system utilizes a quick disconnect connector to connect the power/control cable to the electronics. The equipment has been designed to work with the system components listed in Section 7.0.

RELATED DOCUMENT – MUST COMPLY WITH SCHEDULE DOCUMENT(S):

CERT-IVN MNL

FOR A LIST OF RELEVANT PATENTS AND TRADEMARKS PLEASE SEE CHENTRONICS.COM/LEGAL-NOTICES

ISO 9001 CERTIFIED

IVN/TRULIGHT MANUAL

PAGE 14 OF 28

DRAWN BY: AR
ON: 05/14/21

LAST REV BY: XXX
ON: x/y/z

DCO No.
14194

DWG. No. MNL-IVN

REV. C



TOLERANCE NOTES

FABRICATED TOLERANCES

≥ 2 ft (610 mm) ± 0.250 in (6.4 mm)
< 2ft (610 mm) ± 0.125 in (3.2 mm)

MACHINED TOLERANCES

± 0.050 DECIMAL DIM (1 PLACE)
± 0.010 DECIMAL DIM (2 PLACES)
± 0.005 DECIMAL DIM (3 PLACES)

MNL-IVN

THIS DRAWING OWNED BY **CHENTRONICS**. IT IS CONDITIONALLY LOANED AND IS TO BE RETURNED UPON REQUEST. THE BORROWER BY RECEIVING IT HAS AGREED NOT TO REPRODUCE NOR COPY IT IN WHOLE OR IN PART NOR TO FURNISH INFORMATION FROM IT TO OTHERS NOR TO MAKE ANY USE OF IT THAT IS OR MAY BE INJURIOUS TO **CHENTRONICS**. FOR MORE INFORMATION PLEASE CONTACT **CHENTRONICS** AT +1.607.334.5531.

To connect the power cable to the electronics, first turn the locking nut clockwise by hand until it is seated against the electronics. This will ensure the locking nut is not too far out and will allow the connector to properly seat. Then, align the connector on the cable with the connector on the electronics, insert the connector, and turn the outer barrel clockwise until the banjo fittings on the connector are seated and latched.

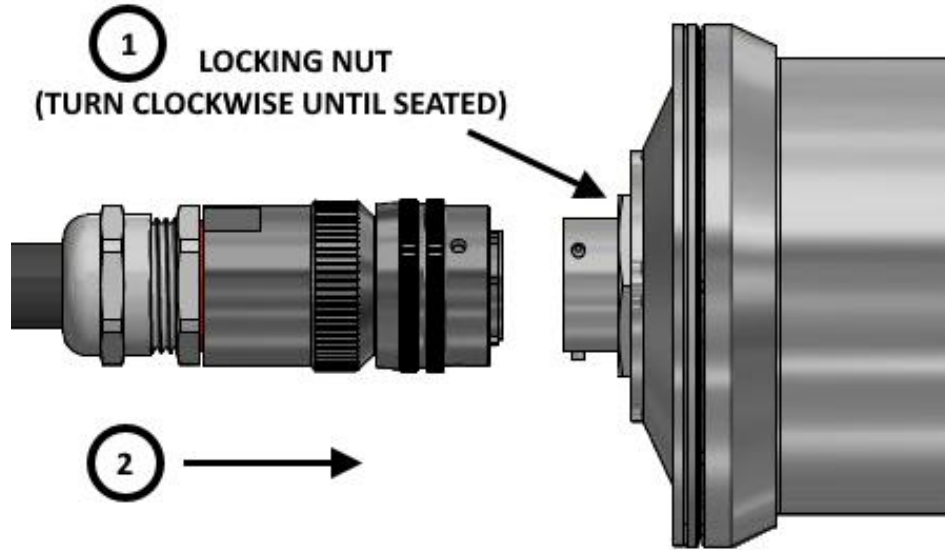

Figure 9: Clear the locking nut then align and insert the cable connector.

5.4 Locking Nut Installation

The equipment features a locking nut that locks the cable to the equipment so that it may not be removed without the use of a tool. This feature is required for some hazardous area installations.

To lock the connector in place, turn the locking nut *counterclockwise* tighten to a torque of 10ftlbs using a wrench. See Figure 10 and Figure 11 for illustration of locking nut tightening.

To remove the cable, turn the locking nut clockwise until it is seated against the electronics, then remove the cable connector by turning the outer barrel counterclockwise until the banjo fittings unseat and the connector unseats and can be removed.

RELATED DOCUMENT – MUST COMPLY WITH SCHEDULE DOCUMENT(S):

CERT-IVN MNL

FOR A LIST OF RELEVANT PATENTS AND TRADEMARKS PLEASE SEE CHENTRONICS.COM/LEGAL-NOTICES

ISO 9001 CERTIFIED

IVN/TRULIGHT MANUAL

PAGE 15 OF 28

DRAWN BY: AR ON: 05/14/21

LAST REV BY: XXX ON: x/y/z

DCO No. 14194

DWG. No. MNL-IVN

REV. C



TOLERANCE NOTES

FABRICATED TOLERANCES

≥ 2ft (610 mm) ± 0.250 in (6.4 mm)
< 2ft (610 mm) ± 0.125 in (3.2 mm)

MACHINED TOLERANCES

± 0.050 DECIMAL DIM (1 PLACE)
± 0.010 DECIMAL DIM (2 PLACES)
± 0.005 DECIMAL DIM (3 PLACES)

MNL-IVN

THIS DRAWING OWNED BY **CHENTRONICS**. IT IS CONDITIONALLY LOANED AND IS TO BE RETURNED UPON REQUEST. THE BORROWER BY RECEIVING IT HAS AGREED NOT TO REPRODUCE NOR COPY IT IN WHOLE OR IN PART NOR TO FURNISH INFORMATION FROM IT TO OTHERS NOR TO MAKE ANY USE OF IT THAT IS OR MAY BE INJURIOUS TO **CHENTRONICS**. FOR MORE INFORMATION PLEASE CONTACT **CHENTRONICS** AT +1.607.334.5531.

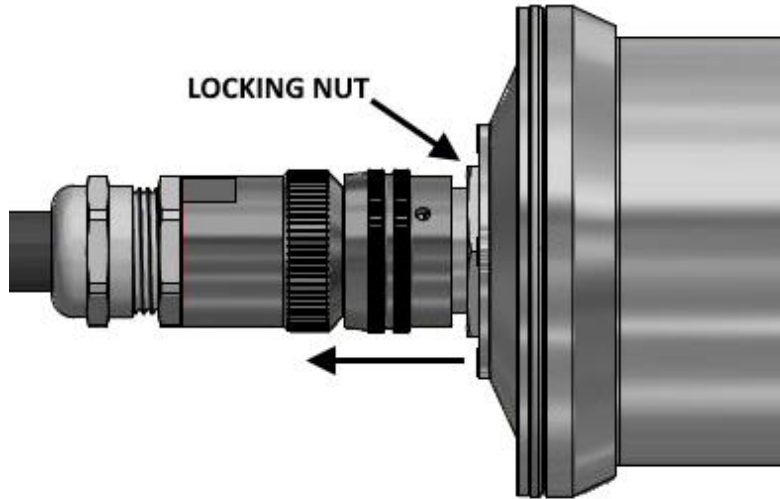

Figure 10: Seat the connector and seat the locknut against the connector barrel.

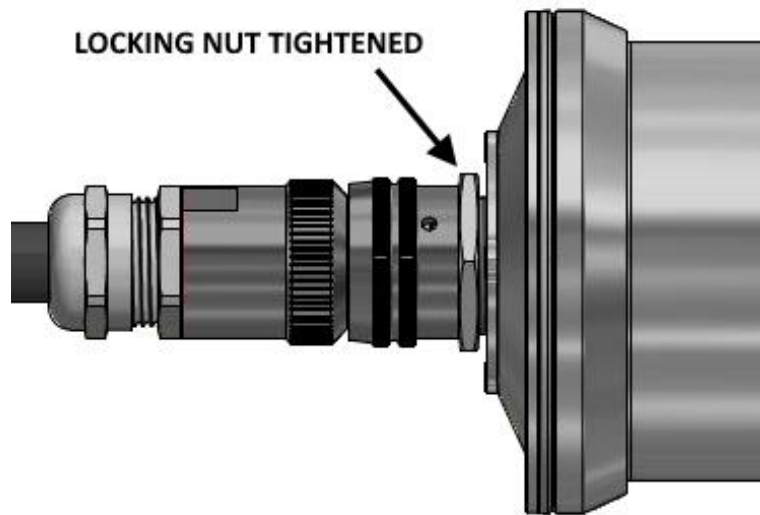

Figure 11: Tighten locking nut against connector barrel.

RELATED DOCUMENT – MUST COMPLY WITH SCHEDULE DOCUMENT(S):

CERT-IVN MNL

FOR A LIST OF RELEVANT PATENTS AND TRADEMARKS PLEASE SEE CHENTRONICS.COM/LEGAL-NOTICES

ISO 9001 CERTIFIED

IVN/TRULIGHT MANUAL

PAGE 16 OF 28

DRAWN BY: AR
ON: 05/14/21

LAST REV BY: XXX
ON: x/y/z

DCO No.
14194

DWG. No. MNL-IVN

REV. C



TOLERANCE NOTES

FABRICATED TOLERANCES

≥ 2 ft (610 mm) ± 0.250 in (6.4 mm)
< 2ft (610 mm) ± 0.125 in (3.2 mm)

MACHINED TOLERANCES

± 0.050 DECIMAL DIM (1 PLACE)
± 0.010 DECIMAL DIM (2 PLACES)
± 0.005 DECIMAL DIM (3 PLACES)

MNL-IVN

THIS DRAWING OWNED BY **CHENTRONICS**. IT IS CONDITIONALLY LOANED AND IS TO BE RETURNED UPON REQUEST. THE BORROWER BY RECEIVING IT HAS AGREED NOT TO REPRODUCE NOR COPY IT IN WHOLE OR IN PART NOR TO FURNISH INFORMATION FROM IT TO OTHERS NOR TO MAKE ANY USE OF IT THAT IS OR MAY BE INJURIOUS TO **CHENTRONICS**. FOR MORE INFORMATION PLEASE CONTACT **CHENTRONICS** AT +1.607.334.5531.



EXPLOSION HAZARD

Do not join or separate any connection to the equipment when the equipment is energized.

Do not connect, disconnect, or service the equipment if an Explosive Atmosphere may be present.

The equipment must be installed and serviced by qualified personnel in accordance with applicable local and national codes, standards, and ordinances.

Substitution of components may impair suitability for Class 1 Division 2 / Zone 2.



RISQUE D'EXPLOSION

Ne pas connecter ou séparer aucune connexion à l'équipement lorsque celui-ci est sous tension

Ne connectez pas, ne débranchez pas et ne réparez pas l'équipement si une atmosphère explosive peut être présente

L'équipement doit être installé et entretenu par du personnel qualifié conformément aux codes, normes et ordonnances locales et nationales applicables.

La substitution de composants peut compromettre l'adéquation à la classe 1, div 2 / zone 2.

RELATED DOCUMENT – MUST COMPLY WITH SCHEDULE DOCUMENT(S):

CERT-IVN MNL

FOR A LIST OF RELEVANT PATENTS AND TRADEMARKS PLEASE SEE CHENTRONICS.COM/LEGAL-NOTICES

ISO 9001 CERTIFIED

IVN/TRULIGHT MANUAL

PAGE 17 OF 28

DRAWN BY: AR
ON: 05/14/21

LAST REV BY: XXX
ON: x/y/z

DCO No.
14194

DWG. No. **MNL-IVN**

REV. **C**



TOLERANCE NOTES**FABRICATED TOLERANCES**

≥ 2 ft (610 mm) ± 0.250 in (6.4 mm)

< 2ft (610 mm) ± 0.125 in (3.2 mm)

MACHINED TOLERANCES

± 0.050 DECIMAL DIM (1 PLACE)

± 0.010 DECIMAL DIM (2 PLACES)

± 0.005 DECIMAL DIM (3 PLACES)

MNL-IVN

THIS DRAWING OWNED BY **CHENTRONICS**. IT IS CONDITIONALLY LOANED AND IS TO BE RETURNED UPON REQUEST. THE BORROWER BY RECEIVING IT HAS AGREED NOT TO REPRODUCE NOR COPY IT IN WHOLE OR IN PART NOR TO FURNISH INFORMATION FROM IT TO OTHERS NOR TO MAKE ANY USE OF IT THAT IS OR MAY BE INJURIOUS TO **CHENTRONICS**. FOR MORE INFORMATION PLEASE CONTACT **CHENTRONICS** AT +1.607.334.5531.

5.5 System Connections

The connections to the IVN / TRULIGHT system are provided in Table 5.5.1 and shown in Figure 12 below. All wires are 20AWG stranded. Use terminal blocks and associated wiring fixing elements suitable for 20AWG stranded wire.

Note: All wiring should be done in accordance with local and national codes, standards, and ordinances.

5.5.1 Table of System Connections

Table 1: System connections.

Wire Label	Wire Color	Signal Name	Function
P	GRN	EARTH	Earth connection
D	RED	24V	24VDC Power Supply (DC+)
C	BLK	24VRET	24VDC Power Return (DC-)
B	YLW	F420	Non-Calibrated 4-20mA flame strength signal output (Return current loop to wire C)
R	GRY	FR2NO	Flame Relay 2 Normally Open Contact
K	ORG	FR12C	Flame Relay 1 and 2 Common Contact
J	PNK	FR1NC	Flame Relay 1 Normally Closed Contact
L	VLT	FR1NO	Flame Relay 1 Normally Open Contact
F	WHT	SRNC	Spark Relay Normally Closed Contact
H	WHT/BLU	SRNO	Spark Relay Normally Open Contact
J	BLU/WHT	SRC	Spark Relay Common Contact
A	BLU	CTS	Ignition System Close-To-Start Input (Short this wire to wire C to spark)
Triax Rod or Harness	n/a	n/a	Igniter and Flame rod drive output (connection depends on PN)

RELATED DOCUMENT – MUST COMPLY WITH SCHEDULE DOCUMENT(S):

CERT-IVN MNL

FOR A LIST OF RELEVANT PATENTS AND TRADEMARKS PLEASE SEE CHENTRONICS.COM/LEGAL-NOTICES

ISO 9001 CERTIFIED

IVN/TRULIGHT MANUAL

PAGE 18 OF 28

DRAWN BY:
AR

ON:
05/14/21

LAST REV BY:
XXX

ON:
x/y/z

DCO No.
14194

DWG. No. MNL-IVN

REV. C



TOLERANCE NOTES

FABRICATED TOLERANCES

≥ 2 ft (610 mm) ± 0.250 in (6.4 mm)
< 2ft (610 mm) ± 0.125 in (3.2 mm)

MACHINED TOLERANCES

± 0.050 DECIMAL DIM (1 PLACE)
± 0.010 DECIMAL DIM (2 PLACES)
± 0.005 DECIMAL DIM (3 PLACES)

MNL-IVN

THIS DRAWING OWNED BY **CHENTRONICS**. IT IS CONDITIONALLY LOANED AND IS TO BE RETURNED UPON REQUEST. THE BORROWER BY RECEIVING IT HAS AGREED NOT TO REPRODUCE NOR COPY IT IN WHOLE OR IN PART NOR TO FURNISH INFORMATION FROM IT TO OTHERS NOR TO MAKE ANY USE OF IT THAT IS OR MAY BE INJURIOUS TO **CHENTRONICS**. FOR MORE INFORMATION PLEASE CONTACT **CHENTRONICS** AT +1.607.334.5531.

5.6 Equipment Earth Bond Location

5.6.1 Earth Bond

The internal earth bond connection is made using the input power/control cable wire P. Connect this wire to earth in the terminating control panel where the other power/control cable wires are terminated.



EXPLOSION HAZARD POTENTIAL ELECTROSTATIC CHARGING HAZARD

Ensure the equipment is properly earth bonded before energizing to prevent a potential buildup of electrostatic charge. A buildup of electrostatic charge can result in potential electrical arcing to earth, which can ignite hazardous atmospheres or result in potential shock hazard from contact with the equipment enclosure.



RISQUE D'EXPLOSION RISQUE DE CHARGE ELECTROSTATIQUE POTENTIELLE

S'assurer que le matériel est correctement mis à la terre avant de mettre sous tension pour éviter une accumulation potentielle de charge électrostatique. Une accumulation de charges électrostatiques peut entraîner de potentiels arcs électriques à la terre, qui peuvent enflammer des atmosphères dangereuses ou entraîner des risques d'électrocution par contact avec le boîtier de l'équipement.

RELATED DOCUMENT – MUST COMPLY WITH SCHEDULE DOCUMENT(S):

CERT-IVN MNL

FOR A LIST OF RELEVANT PATENTS AND TRADEMARKS PLEASE SEE CHENTRONICS.COM/LEGAL-NOTICES

ISO 9001 CERTIFIED

IVN/TRULIGHT MANUAL

PAGE 19 OF 28

DRAWN BY: AR
ON: 05/14/21

LAST REV BY: XXX
ON: x/y/z

DCO No.
14194

DWG. No. MNL-IVN

REV. C



TOLERANCE NOTES

FABRICATED TOLERANCES

≥ 2 ft (610 mm) ± 0.250 in (6.4 mm)
 < 2ft (610 mm) ± 0.125 in (3.2 mm)

MACHINED TOLERANCES

± 0.050 DECIMAL DIM (1 PLACE)
 ± 0.010 DECIMAL DIM (2 PLACES)
 ± 0.005 DECIMAL DIM (3 PLACES)

MNL-IVN

THIS DRAWING OWNED BY **CHENTRONICS**. IT IS CONDITIONALLY LOANED AND IS TO BE RETURNED UPON REQUEST. THE BORROWER BY RECEIVING IT HAS AGREED NOT TO REPRODUCE NOR COPY IT IN WHOLE OR IN PART NOR TO FURNISH INFORMATION FROM IT TO OTHERS NOR TO MAKE ANY USE OF IT THAT IS OR MAY BE INJURIOUS TO **CHENTRONICS**. FOR MORE INFORMATION PLEASE CONTACT **CHENTRONICS** AT +1.607.334.5531.

5.7 System Schematic Diagram

The following schematic block diagram describes equipment functionality. Power/control cable wires for connecting the equipment to installation labeled in blue circles at left.

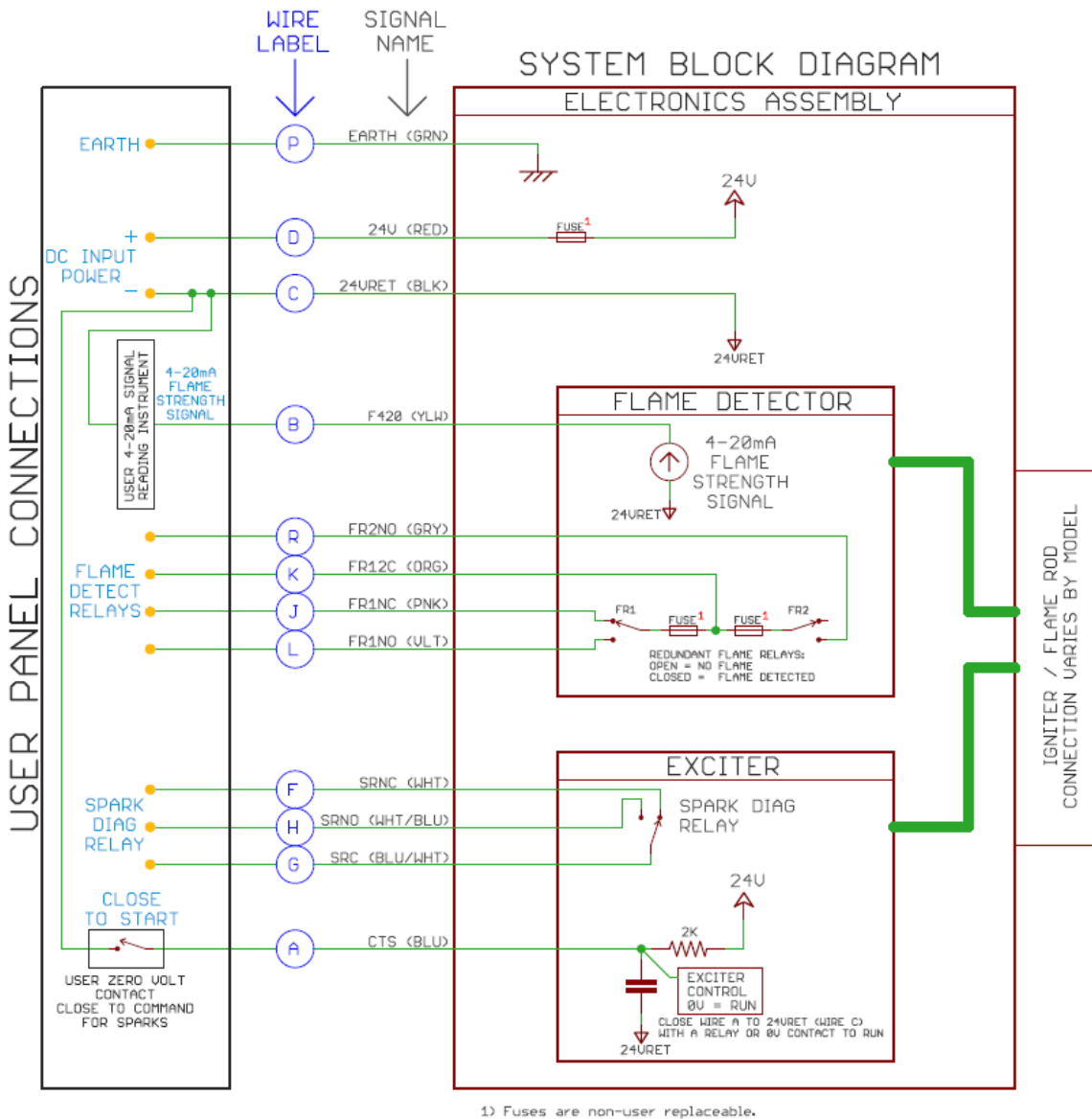

Figure 12: System schematic diagram.

RELATED DOCUMENT – MUST COMPLY WITH SCHEDULE DOCUMENT(S):

CERT-IVN MNL

FOR A LIST OF RELEVANT PATENTS AND TRADEMARKS PLEASE SEE CHENTRONICS.COM/LEGAL-NOTICES

ISO 9001 CERTIFIED

IVN/TRULIGHT MANUAL

PAGE 20 OF 28

DRAWN BY: AR ON: 05/14/21

LAST REV BY: XXX ON: x/y/z

DCO No. 14194

DWG. No. MNL-IVN

REV. C



TOLERANCE NOTES

FABRICATED TOLERANCES

≥ 2 ft (610 mm) ± 0.250 in (6.4 mm)
< 2ft (610 mm) ± 0.125 in (3.2 mm)

MACHINED TOLERANCES

± 0.050 DECIMAL DIM (1 PLACE)
± 0.010 DECIMAL DIM (2 PLACES)
± 0.005 DECIMAL DIM (3 PLACES)

MNL-IVN

THIS DRAWING OWNED BY **CHENTRONICS**. IT IS CONDITIONALLY LOANED AND IS TO BE RETURNED UPON REQUEST. THE BORROWER BY RECEIVING IT HAS AGREED NOT TO REPRODUCE NOR COPY IT IN WHOLE OR IN PART NOR TO FURNISH INFORMATION FROM IT TO OTHERS NOR TO MAKE ANY USE OF IT THAT IS OR MAY BE INJURIOUS TO **CHENTRONICS**. FOR MORE INFORMATION PLEASE CONTACT **CHENTRONICS** AT +1.607.334.5531.

6.0 System Operational Inputs and Outputs

The following functions illustrate the input and output capabilities of the IVN / TRULIGHT system.

6.1 Applying Power to Equipment

To power the equipment, apply 24VDC from wire D (+) to wire C (-). The flame detector circuit will power up and begin looking for flame. The exciter circuit will be in Standby Mode. Refer to Section 6.6 for information on Flame/Spark Indicator functionality in various equipment modes

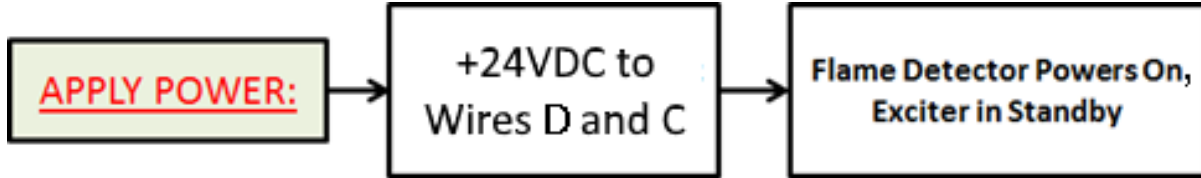

6.2 Flame Detection Feedback

The equipment will close wire R to wire L when a valid flame signal is registered by the flame detector (see Table 1 and Figure 12 for additional flame relay contact options). The flame detector is operational whenever the equipment is powered. Refer to Section 6.6 for information on the Flame/Spark Indicator functionality in various equipment modes.

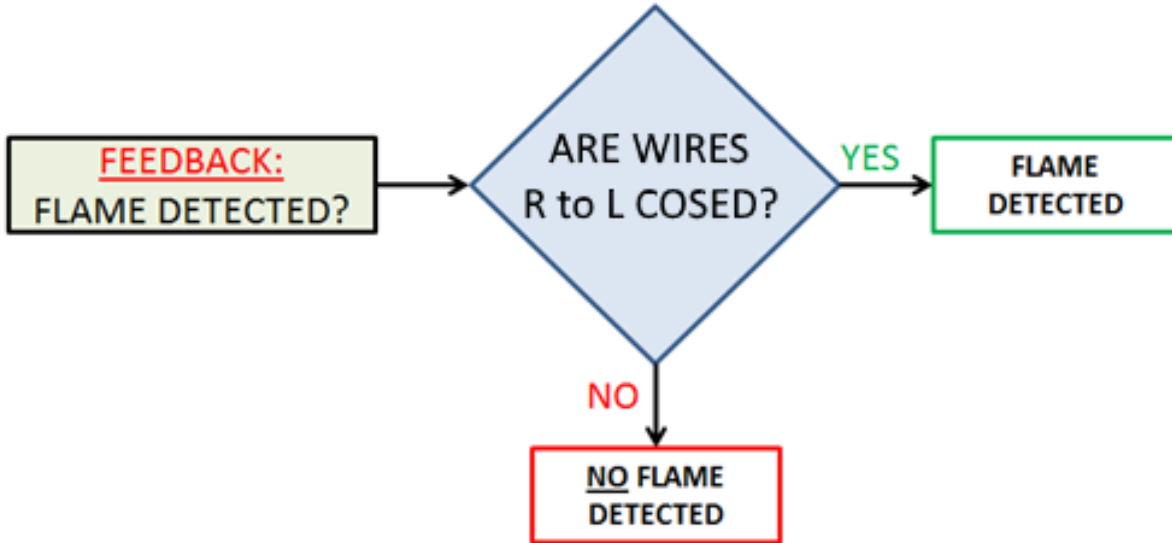

RELATED DOCUMENT – MUST COMPLY WITH SCHEDULE DOCUMENT(S):

CERT-IVN MNL

FOR A LIST OF RELEVANT PATENTS AND TRADEMARKS PLEASE SEE CHENTRONICS.COM/LEGAL-NOTICES

ISO 9001 CERTIFIED

IVN/TRULIGHT MANUAL

PAGE 21 OF 28

DRAWN BY: AR
ON: 05/14/21

LAST REV BY: XXX
ON: x/y/z

DCO No.
14194

DWG. No. MNL-IVN

REV. C



TOLERANCE NOTES

FABRICATED TOLERANCES

≥ 2 ft (610 mm) ± 0.250 in (6.4 mm)
 < 2ft (610 mm) ± 0.125 in (3.2 mm)

MACHINED TOLERANCES

± 0.050 DECIMAL DIM (1 PLACE)
 ± 0.010 DECIMAL DIM (2 PLACES)
 ± 0.005 DECIMAL DIM (3 PLACES)

MNL-IVN

THIS DRAWING OWNED BY **CHENTRONICS**. IT IS CONDITIONALLY LOANED AND IS TO BE RETURNED UPON REQUEST. THE BORROWER BY RECEIVING IT HAS AGREED NOT TO REPRODUCE NOR COPY IT IN WHOLE OR IN PART NOR TO FURNISH INFORMATION FROM IT TO OTHERS NOR TO MAKE ANY USE OF IT THAT IS OR MAY BE INJURIOUS TO **CHENTRONICS**. FOR MORE INFORMATION PLEASE CONTACT **CHENTRONICS** AT +1.607.334.5531.



DANGER



EXPLOSION HAZARD

Verify the flame detector is reporting NO FLAME DETECTED (Flame Relay is deenergized) before attempting to start the burner. This verifies that the flame detector is not reporting the presence of flame when there is none. Failure to verify proper operation of the flame detection system before ignition of a burner could cause an explosion that results in serious injury or death or damage to equipment.



DANGER



RISQUE D'EXPLOSION

Vérifiez que le détecteur de flamme signale AUCUNE FLAMME DÉTECTÉE (le relais de flamme est mis hors tension) avant de tenter de démarrer le brûleur. Ceci vérifie que le détecteur de flamme ne signale pas la présence de flamme alors qu'il n'y en a pas. Le fait de ne pas vérifier le bon fonctionnement du système de détection de flamme avant l'allumage d'un brûleur peut provoquer une explosion entraînant des blessures graves, voire mortelles ou des dommages à l'équipement

6.3 Flame Strength Signal Feedback

The equipment provides a non-calibrated signal of relative flame strength. When a flame is detected, a current level relative to the strength of the flame signal will be sent out on wire B (return this current loop to wire C). The flame signal can be used as a diagnostic tool to trend measured flame signal strength over time or during troubleshooting.

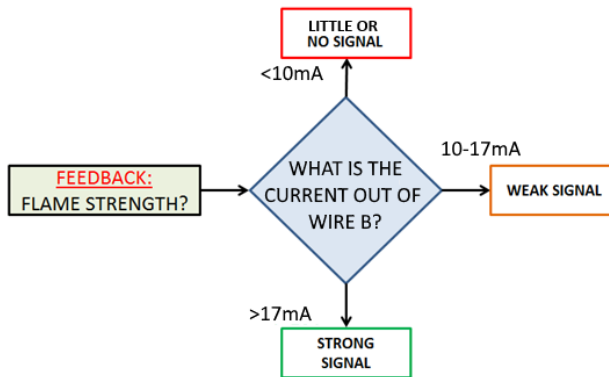

RELATED DOCUMENT – MUST COMPLY WITH SCHEDULE DOCUMENT(S):

CERT-IVN MNL

FOR A LIST OF RELEVANT PATENTS AND TRADEMARKS PLEASE SEE CHENTRONICS.COM/LEGAL-NOTICES

ISO 9001 CERTIFIED

IVN/TRULIGHT MANUAL

PAGE 22 OF 28

DRAWN BY: AR
ON: 05/14/21

LAST REV BY: XXX
ON: x/y/z

DCO No.
14194

DWG. No. MNL-IVN

REV. C



TOLERANCE NOTES

FABRICATED TOLERANCES

≥ 2 ft (610 mm) ± 0.250 in (6.4 mm)
< 2ft (610 mm) ± 0.125 in (3.2 mm)

MACHINED TOLERANCES

± 0.050 DECIMAL DIM (1 PLACE)
± 0.010 DECIMAL DIM (2 PLACES)
± 0.005 DECIMAL DIM (3 PLACES)

MNL-IVN

THIS DRAWING OWNED BY **CHENTRONICS**. IT IS CONDITIONALLY LOANED AND IS TO BE RETURNED UPON REQUEST. THE BORROWER BY RECEIVING IT HAS AGREED NOT TO REPRODUCE NOR COPY IT IN WHOLE OR IN PART NOR TO FURNISH INFORMATION FROM IT TO OTHERS NOR TO MAKE ANY USE OF IT THAT IS OR MAY BE INJURIOUS TO **CHENTRONICS**. FOR MORE INFORMATION PLEASE CONTACT **CHENTRONICS** AT +1.607.334.5531.



DANGER



EXPLOSION HAZARD

The flame strength signal output does not provide proof of flame and must not be used for proof of flame. Use only the Flame Relay output for proof of flame. If the flame strength signal is used for proof of flame, it could provide a misleading result to a control system which could lead to an explosion that results in serious injury or death or damage to equipment.



DANGER



RISQUE D'EXPLOSION

La sortie du signal d'intensité de la flamme ne fournit pas de preuve de flamme et ne doit pas être utilisée comme preuve de flamme. Utilisez uniquement la sortie du relais de flamme comme preuve de flamme. Si le signal d'intensité de la flamme est utilisé comme preuve de flamme, il pourrait en résulter un résultat trompeur pour un système de contrôle, ce qui pourrait provoquer une explosion entraînant des blessures graves, voire mortelles, ou des dommages à l'équipement

6.4 Commanding Exciter to Spark

Closing (shorting) wire A to wire C will command the exciter to spark the igniter. Refer to Section 6.6 for information on the Flame/Spark Indicator functionality in various equipment modes.

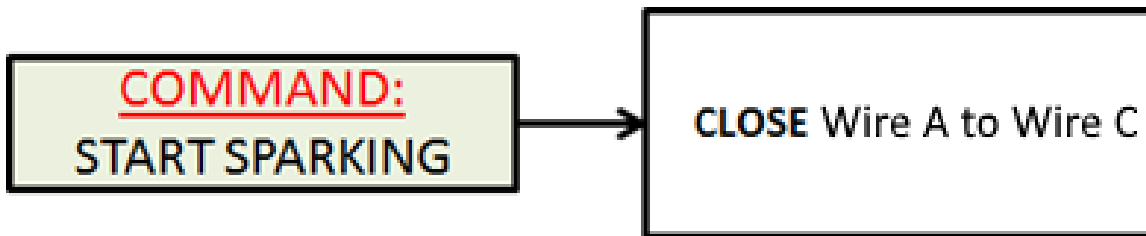

RELATED DOCUMENT – MUST COMPLY WITH SCHEDULE DOCUMENT(S):

CERT-IVN MNL

FOR A LIST OF RELEVANT PATENTS AND TRADEMARKS PLEASE SEE CHENTRONICS.COM/LEGAL-NOTICES

ISO 9001 CERTIFIED

IVN/TRULIGHT MANUAL

PAGE 23 OF 28

DRAWN BY: AR
ON: 05/14/21

LAST REV BY: XXX
ON: x/y/z

DCO No.
14194

DWG. No. MNL-IVN

REV. C



TOLERANCE NOTES

FABRICATED TOLERANCES

≥ 2 ft (610 mm) ± 0.250 in (6.4 mm)
< 2ft (610 mm) ± 0.125 in (3.2 mm)

MACHINED TOLERANCES

± 0.050 DECIMAL DIM (1 PLACE)
± 0.010 DECIMAL DIM (2 PLACES)
± 0.005 DECIMAL DIM (3 PLACES)

MNL-IVN

THIS DRAWING OWNED BY **CHENTRONICS**. IT IS CONDITIONALLY LOANED AND IS TO BE RETURNED UPON REQUEST. THE BORROWER BY RECEIVING IT HAS AGREED NOT TO REPRODUCE NOR COPY IT IN WHOLE OR IN PART NOR TO FURNISH INFORMATION FROM IT TO OTHERS NOR TO MAKE ANY USE OF IT THAT IS OR MAY BE INJURIOUS TO **CHENTRONICS**. FOR MORE INFORMATION PLEASE CONTACT **CHENTRONICS** AT +1.607.334.5531.



STARTLING NOISE

Igniters can make a loud “snapping” or “popping” noise when fired. Anticipate this noise and warn others to expect it before operating the equipment. Alert others in area before operating equipment.



BRUITS SAISSANTS/SURPRENANTS

Les allumeurs peuvent faire un fort bruit de « claquement » ou un bruit « sec » lors de l’allumage. Anticipez ce bruit et avertissez les autres de s’attendre à ce bruit avant de faire fonctionner l’équipement. Alerte tout individu dans la zone avant de faire fonctionner l’équipement.

6.5 Spark Detection Feedback

The equipment provides spark diagnostic feedback. It can communicate with a user’s control system via a relay contact by opening wire G to wire F (see Table 1 and Figure 12 for additional spark diagnostic relay connection options). When the igniter is wearing out, it will begin to skip sparks. When the diagnostic circuit detects skipping sparks, the spark relay will be toggled. This signal can be integrated with a user’s control system to help determine when an igniter is wearing out and needs to be replaced. Refer to Section 6.6 for information on the Flame/Spark Indicator functionality in various equipment modes.

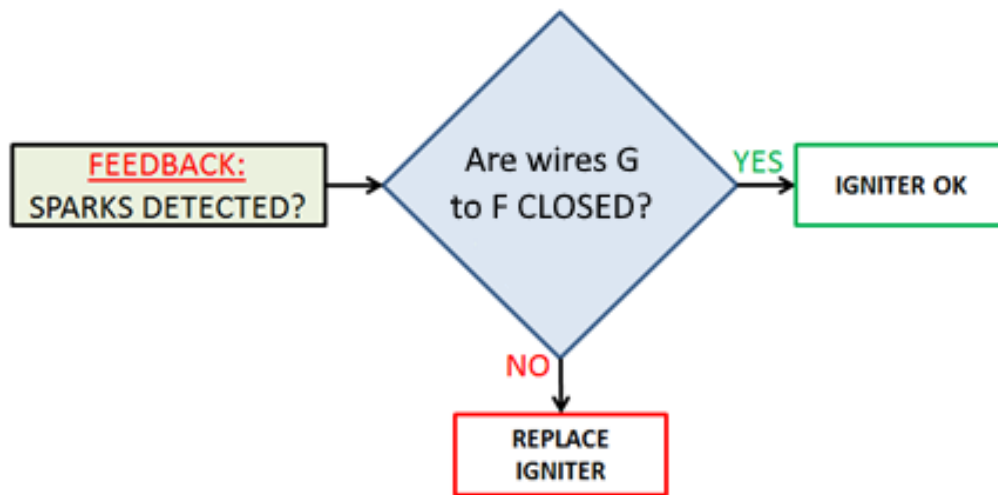

RELATED DOCUMENT – MUST COMPLY WITH SCHEDULE DOCUMENT(S):

CERT-IVN MNL

FOR A LIST OF RELEVANT PATENTS AND TRADEMARKS PLEASE SEE CHENTRONICS.COM/LEGAL-NOTICES

ISO 9001 CERTIFIED

IVN/TRULIGHT MANUAL

PAGE 24 OF 28

DRAWN BY: AR
ON: 05/14/21

LAST REV BY: XXX
ON: x/y/z

DCO No.
14194

DWG. No. MNL-IVN

REV. C



TOLERANCE NOTES

FABRICATED TOLERANCES

≥ 2 ft (610 mm) ± 0.250 in (6.4 mm)
< 2ft (610 mm) ± 0.125 in (3.2 mm)

MACHINED TOLERANCES

± 0.050 DECIMAL DIM (1 PLACE)
± 0.010 DECIMAL DIM (2 PLACES)
± 0.005 DECIMAL DIM (3 PLACES)

MNL-IVN

THIS DRAWING OWNED BY **CHENTRONICS**. IT IS CONDITIONALLY LOANED AND IS TO BE RETURNED UPON REQUEST. THE BORROWER BY RECEIVING IT HAS AGREED NOT TO REPRODUCE NOR COPY IT IN WHOLE OR IN PART NOR TO FURNISH INFORMATION FROM IT TO OTHERS NOR TO MAKE ANY USE OF IT THAT IS OR MAY BE INJURIOUS TO **CHENTRONICS**. FOR MORE INFORMATION PLEASE CONTACT **CHENTRONICS** AT +1.607.334.5531.

6.6 System LED Indicator Ring

The IVN / TRULIGHT system is equipped with a highly visible LED indicator ring at the back of the equipment. This indicator ring communicates the equipment's operating modes covering flame detector status, ignition status, and warning/fault status of the equipment.

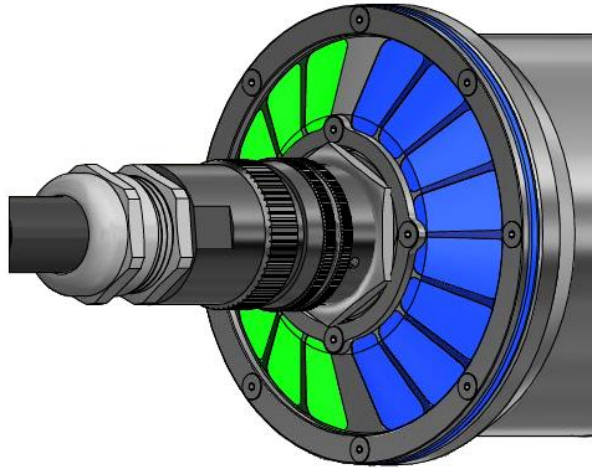

Figure 13: LED Indicator Ring.

6.6.1 Power ON, Ignition System in Standby

When the ignition system is in Standby mode, the entire indicator ring will display the flame detection status: **red** = no flame detected, and **green** = flame detected.

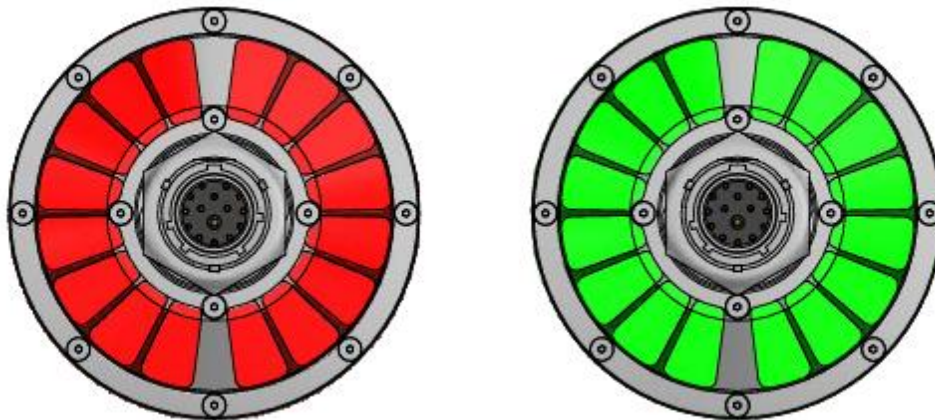

Figure 14: Ignition System in Standby - No Flame status (left) and Flame Detected status (right).

RELATED DOCUMENT – MUST COMPLY WITH SCHEDULE DOCUMENT(S):

CERT-IVN MNL

FOR A LIST OF RELEVANT PATENTS AND TRADEMARKS PLEASE SEE CHENTRONICS.COM/LEGAL-NOTICES

ISO 9001 CERTIFIED

IVN/TRULIGHT MANUAL

PAGE 25 OF 28

DRAWN BY: AR
ON: 05/14/21

LAST REV BY: XXX
ON: x/y/z

DCO No.
14194

DWG. No. **MNL-IVN**

REV. **C**



TOLERANCE NOTES

FABRICATED TOLERANCES

≥ 2 ft (610 mm) ± 0.250 in (6.4 mm)
< 2ft (610 mm) ± 0.125 in (3.2 mm)

MACHINED TOLERANCES

± 0.050 DECIMAL DIM (1 PLACE)
± 0.010 DECIMAL DIM (2 PLACES)
± 0.005 DECIMAL DIM (3 PLACES)

MNL-IVN

THIS DRAWING OWNED BY **CHENTRONICS**. IT IS CONDITIONALLY LOANED AND IS TO BE RETURNED UPON REQUEST. THE BORROWER BY RECEIVING IT HAS AGREED NOT TO REPRODUCE NOR COPY IT IN WHOLE OR IN PART NOR TO FURNISH INFORMATION FROM IT TO OTHERS NOR TO MAKE ANY USE OF IT THAT IS OR MAY BE INJURIOUS TO **CHENTRONICS**. FOR MORE INFORMATION PLEASE CONTACT **CHENTRONICS** AT +1.607.334.5531.

6.6.2 Power ON, Ignition System ON

When the ignition system is ON and running, the left half of the indicator ring will display the ignition system status in **blue** while the right half of the indicator ring will continue to display the flame detection status: right half **red** = no flame detected, and right half **green** = flame detected.

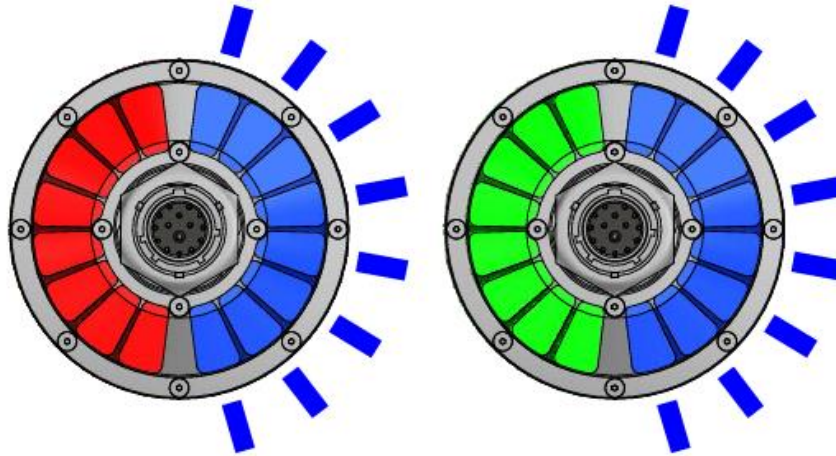

Figure 15: Ignition System ON - No Flame status (left) and Flame Detected status (right).

When the ignition system is ON, the left half of the indicator will be lit in **blue** when the exciter is attempting to spark the igniter. When **blue**, this indicator is referred to as the Spark Indicator. The Spark Indicator will briefly flash/blink off each time a spark output current is detected. When wearing out, an igniter will begin to skip sparks. This can be visually verified by the Spark Indicator not flashing consistently, or missing blinks. When the igniter is completely worn out, the Spark Indicator will remain on solid **blue** when attempting to spark. For information regarding the spark diagnostic relay output, see section X.

6.6.3 Power ON, Fault Modes

The equipment contains onboard temperature sensing and will go into warning/fault modes if the temperature of the equipment is outside the acceptable operating temperature range. There are two warning/fault modes: Over/Under Temperature Warning, and Permanent Fault.

Over/Under Temperature Warning status is communicated through a blinking yellow indicator ring. In this warning mode, the equipment has registered that it is outside its operating temperature range and will shut down the flame detector circuit until the temperature returns to acceptable operating range. This is a warning mode and the equipment is recoverable from this mode.

RELATED DOCUMENT – MUST COMPLY WITH SCHEDULE DOCUMENT(S):

CERT-IVN MNL

FOR A LIST OF RELEVANT PATENTS AND TRADEMARKS PLEASE SEE CHENTRONICS.COM/LEGAL-NOTICES

ISO 9001 CERTIFIED

IVN/TRULIGHT MANUAL

PAGE 26 OF 28

DRAWN BY: AR
ON: 05/14/21

LAST REV BY: XXX
ON: x/y/z

DCO No.
14194

DWG. No. MNL-IVN

REV. C



TOLERANCE NOTES

FABRICATED TOLERANCES

≥ 2 ft (610 mm) ± 0.250 in (6.4 mm)
< 2ft (610 mm) ± 0.125 in (3.2 mm)

MACHINED TOLERANCES

± 0.050 DECIMAL DIM (1 PLACE)
± 0.010 DECIMAL DIM (2 PLACES)
± 0.005 DECIMAL DIM (3 PLACES)

MNL-IVN

THIS DRAWING OWNED BY **CHENTRONICS**. IT IS CONDITIONALLY LOANED AND IS TO BE RETURNED UPON REQUEST. THE BORROWER BY RECEIVING IT HAS AGREED NOT TO REPRODUCE NOR COPY IT IN WHOLE OR IN PART NOR TO FURNISH INFORMATION FROM IT TO OTHERS NOR TO MAKE ANY USE OF IT THAT IS OR MAY BE INJURIOUS TO **CHENTRONICS**. FOR MORE INFORMATION PLEASE CONTACT **CHENTRONICS** AT +1.607.334.5531.

Permanent Fault status is communicated through a solid yellow indicator ring. When the equipment is egregiously over heated due to extreme high ambient temperature conditions, the equipment will permanently disable the flame detector. This is a permanent fault condition, and the equipment *cannot* be recovered. This condition is set by a thermal fuse. The fuse will blow if the equipment is subjected to great than 110C regardless of power applied to the equipment or operating condition.

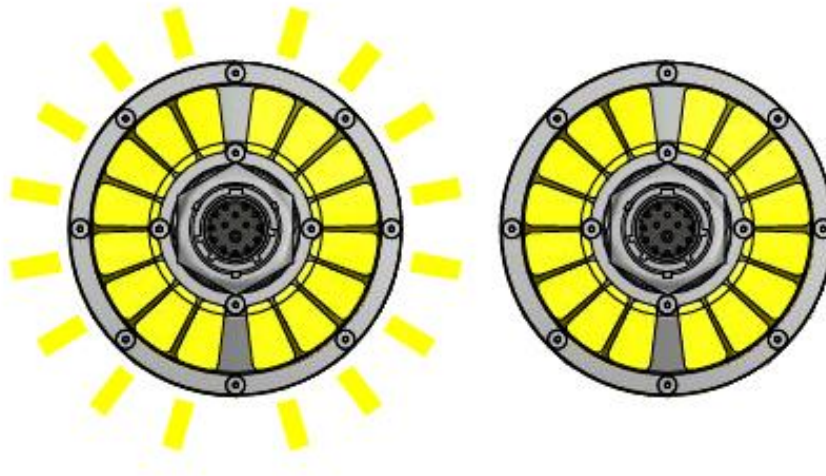

Figure 16: Over/Under Temperature Warning fault status (left) and Permanent Fault status (right).

7.0 Standard Components and Accessories

The following is a sample of standard parts available for use with the IVN / TRULIGHT system. For additional parts and technical drawings please contact Chentronics.

7.1 Standard System Components

7.1.1 PN 04001000 / PN 04001090 Standard Components

Igniter Assembly (Igniter/Flame rod tip end):	PN 04000500
Triaxial Base Rod:	PN 04000400
Power/Control Cable:	PN 03001000

7.1.2 PN 04000900 / PN 04000990 Standard Components

12 Series Igniter:	PN 12000500
12 Series Extension Rod:	PN 12000400
Base Rod:	PN 02FR0100, PN 12FR0100
Flame Rod:	PN:12FR0101
Power/Control Cable:	PN 03001000

RELATED DOCUMENT – MUST COMPLY WITH SCHEDULE DOCUMENT(S):

CERT-IVN MNL

FOR A LIST OF RELEVANT PATENTS AND TRADEMARKS PLEASE SEE CHENTRONICS.COM/LEGAL-NOTICES

ISO 9001 CERTIFIED

IVN/TRULIGHT MANUAL

PAGE 27 OF 28

DRAWN BY: AR
ON: 05/14/21

LAST REV BY: XXX
ON: x/y/z

DCO No.
14194

DWG. No. **MNL-IVN**

REV. **C**



TOLERANCE NOTES

FABRICATED TOLERANCES

≥ 2 ft (610 mm) ± 0.250 in (6.4 mm)
< 2ft (610 mm) ± 0.125 in (3.2 mm)

MACHINED TOLERANCES

± 0.050 DECIMAL DIM (1 PLACE)
± 0.010 DECIMAL DIM (2 PLACES)
± 0.005 DECIMAL DIM (3 PLACES)

MNL-IVN

THIS DRAWING OWNED BY **CHENTRONICS**. IT IS CONDITIONALLY LOANED AND IS TO BE RETURNED UPON REQUEST. THE BORROWER BY RECEIVING IT HAS AGREED NOT TO REPRODUCE NOR COPY IT IN WHOLE OR IN PART NOR TO FURNISH INFORMATION FROM IT TO OTHERS NOR TO MAKE ANY USE OF IT THAT IS OR MAY BE INJURIOUS TO **CHENTRONICS**. FOR MORE INFORMATION PLEASE CONTACT **CHENTRONICS** AT +1.607.334.5531.



! DANGER



EXPLOSION HAZARD

Flame simulating devices are for equipment troubleshooting purposes only. NEVER use any flame simulating device to provide false flame indication during normal operation. Indication of a flame when one is not present will defeat devices that monitor safe operation of equipment and can result in serious injury or death or damage to equipment.



! DANGER



RISQUE D'EXPLOSION

Les dispositifs de simulation de flamme sont uniquement à des fins de dépannage du matériel. NE JAMAIS utiliser un dispositif de simulation de flamme pour fournir une fausse indication de la flamme pendant le fonctionnement normal. L'indication d'une flamme quand il n'y en a pas ira à l'encontre des dispositifs qui contrôlent le fonctionnement en sécurité de l'équipement et peut entraîner des blessures graves ou la mort ou des dommages matériels.

8.0 Warranty Instructions

For warranty related inquires please contact Chentronics at TEL: +1.607.334.5531 or info@chentronics.com

9.0 Technical Support

For technical support related inquires beyond the scope of this Installation and Operation Manual, please contact Chentronics at TEL: +1.607.334.5531 or info@chentronics.com

RELATED DOCUMENT – MUST COMPLY WITH SCHEDULE DOCUMENT(S):

CERT-IVN MNL

FOR A LIST OF RELEVANT PATENTS AND TRADEMARKS PLEASE SEE CHENTRONICS.COM/LEGAL-NOTICES

ISO 9001 CERTIFIED

IVN/TRULIGHT MANUAL

PAGE 28 OF 28

DRAWN BY: AR
ON: 05/14/21

LAST REV BY: XXX
ON: x/y/z

DCO No.
14194

DWG. No. MNL-IVN

REV. C

